

Finfloor

LAMINATE



Accessories

FLOORING < > TRA

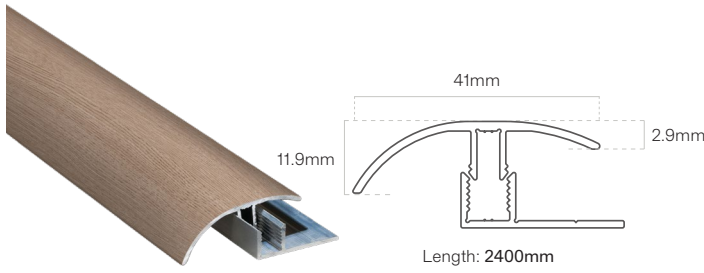

TRANSITION PROFILE

To be used when the installation of your laminate floor incorporates a union with a floor of a different height.

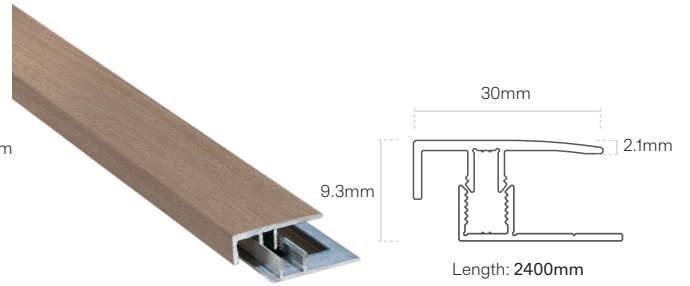

END PROFILE

To be used when you want to finish off your installation with little or no protrusion. Very useful when finishing against a window or against furniture baseboards or bathroom fixtures.

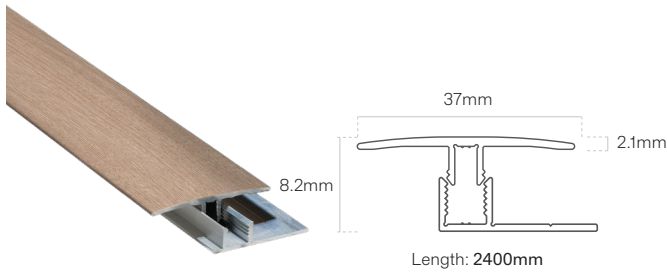

EXPANSION PROFILE

For use in doorways and when the dimensions of the room require it. It is designed to facilitate the expansion and contraction of the floor.

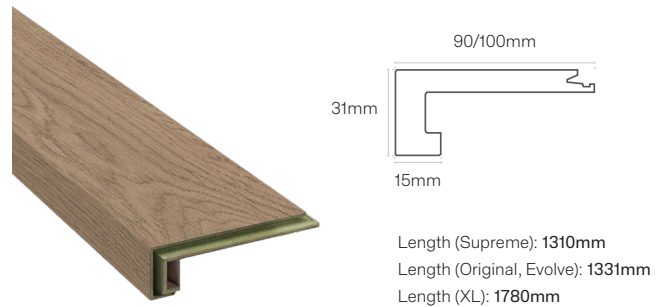

STAIR NOSING

Our nosing adds the finishing touch to your rooms with steps or stairs, blending with the design you select for your floor.



PERIMETER APPLICATION SILICONE

Finsa neutral silicone filler prevents water seepage under floating floors in kitchen and bathroom installations. Its high level of elasticity allows the floor to expand without losing its watertightness. Good adhesion on building materials such as concrete, cement, brick, natural stone, metals, wood, fibre backing boards, PVC or glass.

Capacity 80ml | Yield 10m²



JOINT SEALANT

Finsa joint sealant blocks water seepage between the laminate floor planks and prevents further damage to the installation. Its application helps to prolong the life of the product and allows the use of Finfloor in kitchens and bathrooms with its corresponding guarantee.

Capacity 125ml | Yield 10-15m²

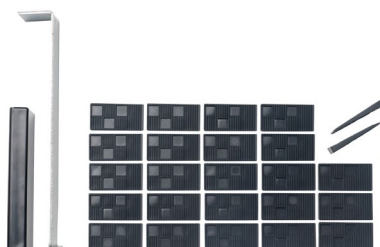

INSTALLATION KIT

This basic installation kit consists of 24 spacer wedges that help maintain the expansion gap between the floor and the walls (or any fixed element) during installation, and an impact block to avoid damaging your Finfloor in case of impact.

AVAILABLE IN THESE COLOURS

XL



SWEETNESS
VERA OAK



TRIBUTE
VERA OAK



LEGACY
VERA OAK

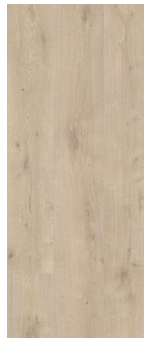

CLARITY
VERA OAK



CENTURY
VERA OAK



HONEY
EYRE OAK

EVOLVE



ESSENCE
KALMAR OAK



SOTAVENTO
FADO OAK

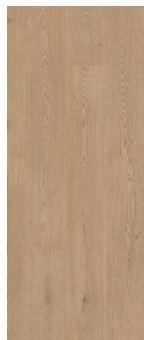

FADO
GAVIA OAK



GOLDEN
VIENA OAK



PARDO
KALAS OAK



NOZ
KALAS OAK

SUPREME



SABLE
SELENA OAK



DOLOMITES
GAIA OAK



GOLDEN
SELENA OAK



TOASTED
SELENA OAK

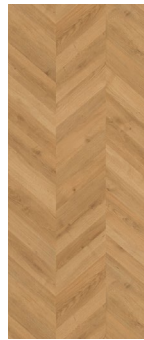

DIJON
CHEVRON



NANTES
CHEVRON

ORIGINAL



CHIC OAK



MAGARI OAK



CRESCENDO
OAK



POLKA OAK



PARAMOUNT
OAK



CALCIC OAK



TAUPE OAK



BANFF OAK

UNDERLAY



BELGOTEX AQUA ELITE UNDERLAY

Engineered to significantly reduce both reflected footfall and transmitted noise from upper-story traffic, Aqua Elite ensures a serene and peaceful environment below. Whether you're walking softly or bustling around, this underlay keeps your space quiet and comfortable.

Designed to work seamlessly with underfloor heating and cooling systems, Aqua Elite offers year-round comfort. When installed over a flat, smooth sub-floor, it provides a firm, luxurious feel underfoot, enhancing the longevity and performance of your new floor for years to come.

Roll Length **25m** | Roll Width **1m** | Thickness **2.5mm**
Water Vapour Diffusion Resistance (SD) **>75m**
Compression Strength (CS) **109kPa**

BELGOTEX AQUA PERFORMANCE UNDERLAY

Aqua Performance sets the standard for quality in floating floor underlays. At Belgotex, we prioritize indoor air quality, which is why we use only the finest materials to ensure a safe and healthy environment for you and your family. Built to last, Aqua Performance is guaranteed to protect your flooring investment for years to come, featuring an integrated vapour barrier and convenient peel-and-stick tape for easy installation.

Roll Length **50m** | Roll Width **1m** | Thickness **2.0mm**
Water Vapour Diffusion Resistance (SD) **>75m**
Compression Strength (CS) **42kPa**



Belgotex®

Finfloor Distributor

Contact Us

P 0800 377 753 | W belgotex.co.nz | E info@belgotex.co.nz

