

Floating Wood Floor Install Guide

This guide outlines the installation of VidaSpace flooring products to internal applications in buildings covered by New Zealand building code.

Safety must be paramount on every installation. All electrical equipment must be PAT tested and labelled and all cutting tools such as jigsaws, circular and bench saws must have guards fitted and cutting must be carried out on a suitable bench. You must also wear suitable work wear and remove or make safe any loose items such as jewellery. Safety is your responsibility.

The installer must be suitably trained and knowledgeable with wood flooring installations.

Engineered wood flooring can be installed as a floating floor, fully bonded or nailed/screwed down. This document covers floating installation.

The following topics are covered by this document, for further information or for advice on any subject not covered here, please contact VidaSpace:

- Environmental Conditions
- Subfloor Preparation
- Installation
- Underfloor Heating
- HVAC heating/climate control
- Floor Protection

N.B The final responsibility for the installation lies with the installer. It is the duty of the installer to inspect materials prior to installation and notify VidaSpace of any potential material defects prior to installation. Installed materials are deemed to have been accepted.

Environmental Conditions:

The building must be watertight with all windows and doors fitted and all wet trades complete before taking delivery of materials and before any wood flooring installation can take place.

Always check the ambient room temperature and humidity which should be maintained at a constant level, between 18°C (64°F) and 22°C (72°F) with a relative humidity, between 45% - 65%RH prior to, during and for the whole life of the wood flooring. Try to avoid extremes of low or high temperatures as this will negatively affect the stability of the wood flooring.

Acclimatise the wood flooring in the room where the wood is to be fitted for at least 72 hours prior to the installation. The timber material should be maintained in their original packaging in this period. Only remove the materials from their packaging just before installation. The wood should be stored out of direct sunlight, away from walls and radiators and on battens fully supporting the wood to prevent a build of heat on the bottom boards.

Acclimatising is used to balance the wood flooring with the environment in the installation area.

If the temperature of the wood is at an equilibrium balance (the same as the room) and the moisture level of the wood is 8%(±2%) then you can assume that the timber does not require any further acclimatisation.

Keep the room temperature constant by using the heating set at minimum 15°C (59°F) or if there are problems with the permanent heating other forms of heating such as convector heaters can be used.

Do not use gas-type heaters as these will generate extra moisture in the air.

Infra-red type heaters do not generally warm the fabric of the room or the wood, they tend to only warm the person or item close to the heater.

Low humidity can cause the wood to shrink and high level to cause expansion. Common causes of low humidity are using the heating at too high temperature, open fires and wood burners. High humidity is commonly caused by poor ventilation.

We recommend using a Digital Gauge to monitor the humidity and temperature level that can be easily adjusted by either placing moisture in the room (plants that are watered regularly or receptacles of water) or ventilating the room to reduce high levels of humidity. A humidifier/de-humidifier can also be used to control the atmosphere.

As a general rule, rooms/areas should be adequately ventilated to prevent a build of moisture in the environment. Care must also be given to rooms that are only heated when in use and with the heating switched fully off at other times. This can cause a buildup of humidity if the room is closed and not ventilated immediately after usage. The build of humidity / moisture will generally increase the moisture level of the wood flooring. The next time the room is used, the heating can dry out the moisture in the surface of the wood, causing cupping.

Wood will naturally change in size during seasonal variations in temperature and humidity.

During summer the humidity is generally at its highest level, hence the wood joins should be reasonably tight together. During the winter, when heating is commonly used, the humidity levels are generally lower and will produce small gaps between the joins. This occurrence is not a manufacturing or installation fault.

Subfloor Preparation:

The subfloor must be sound, dry, free from contamination and flat to maximum 3mm of level variance under a 2m long straight edge, at any point across the subfloor.

Where a wooden floor is to be installed using a floating method, a structural subfloor must always be in place beneath the floor finishes. Please consult VidaSpace if there is any question relating to substrate suitability.

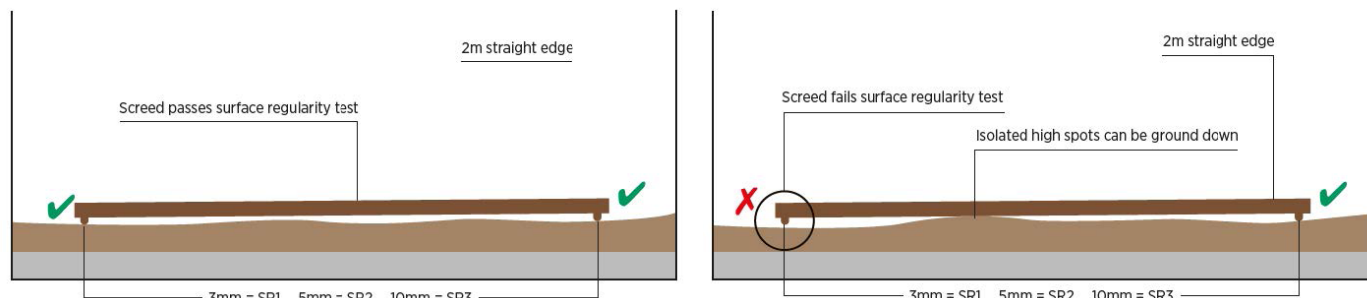

Please Note: Where underfloor heating is present, only engineered floors with a click-system locking profile (e.g. Pure-plank, Europlank) are appropriate to be floated. Tongue and Grooved engineered floors should be installed in a fully bonded method over UFH.

Screeded Substrates

Cementitious (sand and cement) / Calcium Sulphate (Anhydrite):

The subfloor must be sound with no friable areas, free of laitance and dry. The moisture content of solid sub-floors must be checked in accordance with [British Standards Annex A](#).

This is carried out using a Hygrometer set on top of the screed or by inserting a sleeve into the screed, (the sleeve method is not recommended with underfloor heating to avoid the risk of damage to the pipes).

For screed substrates, the moisture reading must be less than 75% Relative Humidity (RH) for a floating installation.

Where there is a cementitious substrate, if the reading is above 75% RH and below 95% RH, we recommend using the Marldon MXS 140 two-part epoxy damp proof membrane (DPM). The DPM must be applied in accordance with the manufacturer's instructions. Marldon MXS 140 DPM (or any other epoxy DPM) cannot be used on anhydrite-type screeds.

A poured or pumped screed rarely achieves the required SR1 levels and it is recommended that a self-levelling compound be used prior to timber flooring installation.

Timber Substrates

The timber sub-floor must be sound, tested for vertical movement (which should be less than 5mm) and dry, tested using a spike-type meter. The moisture content of the subfloor should be less than 14% and within $\pm 2\%$ of the wood floor being installed.

All suspended wood floors must have suitable through ventilation normally delivered by air bricks in the outside walls. Any wood sub-floor that has a higher moisture level than 14% should be investigated. They must also be free of infestations such as wood-rotting fungi and wood boring insects.

Note: We recommend using an asphalt impregnated paper on wood and solid sub-floors, to reduce/ prevent residual moisture affecting the wood flooring.

Unsuitable Substrates

A floated floor must not be installed over a substrate with a low compressive strength. A typical example of this would be extruded insulation panels (PIR, PUR, EPS, XPS etc.) which do not offer the necessary density for a direct installation. Installation directly to a material of this type can lead to flexing (and potentially failure) at the joints between planks and excessive deflection in the finished flooring. These materials must be over-boarded with a higher density material prior to timber flooring installation.

Installation:

Plank format flooring is designed to be installed in a randomly staggered pattern where the off-cut from the end of the previous row is used to start the following row, provided its length is equal to at least half the width of the plank. If another pattern is required for the project, then VidaSpace must be consulted prior to order of the materials.

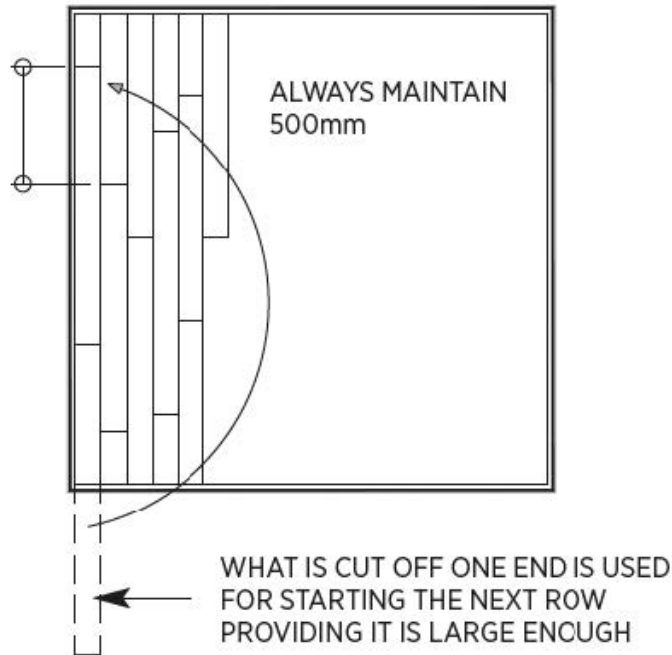

In order to achieve a harmonious blend of tones throughout the floor, material should be taken from several packs and mixed during the installation. Working from 3-4 packs at a time creates a blend of tones from the variation in the raw material. Colour variety is inherent to all wooden floors and is a key feature in the choice of real wood material for any interior scheme.

It is also important to keep the atmosphere constant during and for at least 24 hours after the installation (particularly overnight) when temperatures can drop causing variations in the atmosphere and may not allow the glue to cure effectively in glued T&G installations.

Always create an unfilled expansion gap of a minimum 12mm on areas of less than 25 m² and a minimum of 15mm on larger areas.

Areas in excess of 10 linear meters x 8m width of the boards may require extra expansion between the boards and intermediate expansion in the length. Expansion gaps can be covered using a skirting board or beading/scotia.

Threshold profiles should be installed in all doorways, arches or narrow sections that lead from one room/area to the next. Perimeter details which do not allow for a skirting or scotia must have a threshold detail which covers the expansion gap.

These thresholds must allow for the required expansion and contraction. Door frames and architraves can be undercut to allow the wood to slide underneath, still allowing for the expansion.

Note: Never undercut newel posts as these are structural sections of the stairs.

Underlays

Floating installations of wood flooring require the floor to be installed onto an underlay (unless the product has an incorporated underlay backing). Underlays differ in their acoustic performance and ability to isolate substrate moisture. Ensure that the underlay being used for the installation meets the requirements of the project.

Underlays such as Vidaspaces' ProVent have an incorporated overlapping vapour barrier. This utilises a self-adhesive strip incorporated into an overlapping fold in the polythene face of the underlay which is used to secure the adjacent strips of underlay to one another and form a continuous vapour barrier.

Where foil-backed underlays (such as VidaSpaces' Kingley) are used, all the joins in the underlay should be secured / sealed with a foil or waterproof tape to ensure the formation of a vapour barrier. Undatech is a foil-backed underlay to be used foil side down.

A vapour barrier is not a DPM and an adequate surface DPM is required where substrate moisture content is found to be above 75%RH.

Specific to Click-System Floors

Click-system locking profiles do not require the application of glue to the joints, except where trimmed adjustments to the joint profile need to be made (e.g. under door frames or undertaking board replacements).

Remove any damage or debris from the joint prior to installation of the flooring materials.

Always use a tapping block to fit planks together along the long edge of the boards first. At an angle, insert the 'tongue' / male section of the joint into the opposing joint section on the adjacent board – this will normally sit at a 30° angle from the subfloor. Tap along the length of the plank, knocking the boards together laterally to ensure that the joint is fully engaged – the plank should sit flat to the subfloor after doing this. Short ends of planks can either be levered together (joint-type 2G) or engaged vertically (joint-type 5G, 5S etc.) once the long-edge is engaged.

Note: Forcing the plank down vertically without first tapping together from the side risks the joint being incorrectly positioned and can lead to gapping or tension within the floor.

Specific to Tongue & Groove Floors

Floated T&G boards are fixed together by applying glue (D3 or D4 type) in a continuous bead along all grooves. The glue should be applied to the upper corner of the groove to ensure full coverage around the tongue. To check for full coverage around the tongue remove an occasional board.

Spot-gluing leaves the joint weak. Applying the adhesive to the bottom of the groove with the excess adhesive falling downwards means that the adhesive does not wrap fully around the tongue. Always remove excess adhesive from the face of the board immediately with a moist cloth (not wet) or as per adhesive manufacturer's instructions.

We recommend using clamps across the boards to prevent the adhesive pushing the boards apart. Adhesive is hydraulic and until the pressure of pushing the boards together has dispersed, boards tend to open slightly.

Glue Application location:

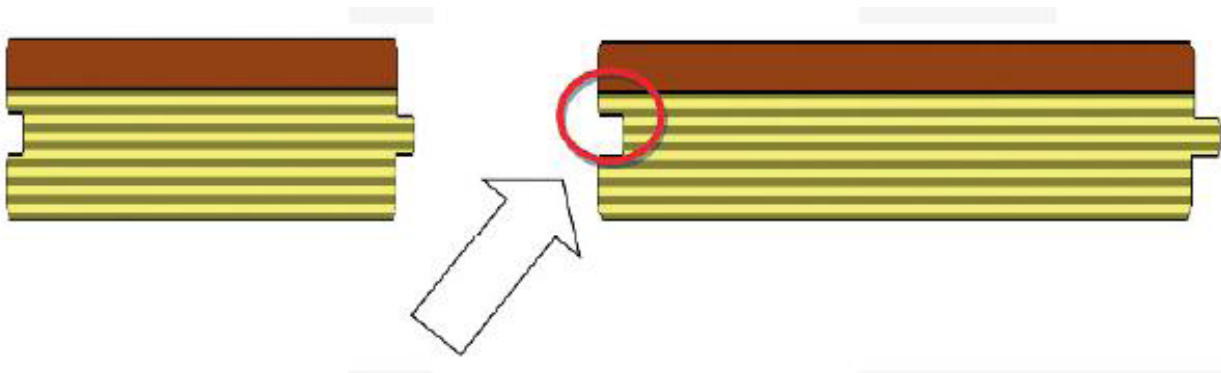

Underfloor Heating (UFH):

We advise using a water pipe UFH systems that is set into a screed or electric type set into a smoothing compound under wood flooring.

Electric cable systems must have a minimum of 8mm coverage above the cables using a reinforced smoothing compound.

Heating elements (pipes or cables) should not be in direct contact with the reverse of the plank or the underlay. This is to avoid over-drying of the timber materials through direct transfer of heat into the wood. Electric mats or water pipes that are placed on top of screeds in routed panels must have a distribution board fitted above them to ensure an even heat distribution to the underside of the engineered board. This is typically a layer of plywood, particleboard or dry-screed panel. Aluminium spreader plates sit below pipes and do not offer separation of heating elements from the underside of the flooring.

Note: Some systems can create hot spots (when rugs or other items not on feet are placed directly onto the wood floor) which will negatively affect the stability of the wood flooring.

To ensure the surface of the wood flooring does not exceed 27°C (81°F), we recommend temperature probe(s) be installed within the subfloor build up to regulate the surface temperature. These should be located in each room / zone.

Note: Wall mounted, or free-standing thermostats placed >500 mm off the floor surface can allow higher temperatures at floor level.

Embedded UFH Systems in Screeds

Prior to delivery, the underfloor heating must be commissioned and have been working for at least three weeks. Our advice is to gradually build up the UFH temperature to maximum for the first 5 days, run for 3–5 days and then allow the heating to cool gradually to the off position.

We would recommend carrying out at least two cycles to ensure any moisture is released. Once these cycles have been undertaken, switch off the heating and any artificial drying aids four days prior to setting and taking humidity readings.

Never take humidity (or any other moisture tests) readings with the heating or other drying aids such as de-humidifiers on.

UFH Systems Within or Beneath a Structural Deck

Unlike embedded water pipe subfloor heating systems, those heating systems situated within or beneath a structural deck are not generally commissioned prior to the installation of the floor coverings.

Where commissioning is to be undertaken with VidaSpace flooring installed over this type of system, the below steps should be followed in order to prevent the occurrence of an excessive moisture and temperature gradient between the VidaSpace timber flooring and the surrounding environment and/or substrate:

- All screeds situated beneath bearers should be tested for moisture to ensure that they do not have levels higher than 75%RH (2.5%CM)
- The environment should be tested and recorded to ensure that the environmental RH remains in the range of 45–65%.
- Floor protection must always be lifted prior to the commissioning process and should not be placed on the flooring at any stage while the heating system is in operation.
- Flow temperature should be set at the lowest possible setting and not above 30°C in the first instance.
- Temperature should be increased by a maximum of 2°C per day or 5°C every 3 days if the controls do not allow adjustments in 2°C increments.
- Surface temperature readings should be taken and recorded in the morning and evening of each day during the commissioning process to ensure that a surface temperature of 27°C is not exceeded in the flooring.

Once the maximum flow temperature has been established to ensure surface temperatures are within permissible levels, tamper-proof controls should be implemented to ensure that this upper flow temperature is not exceeded.

Underfloor heating systems should be connected to a surface probe routed into the underside of the flooring or surface of the structural deck to give true surface readings. Those systems controlled by ambient thermostats generally offer an inadequate measure of control.

The care manual handed to the end user should highlight the requirement for heating systems to be increased gradually when moving into the colder months.

Information on the thermal conductivity/resistance of VidaSpace products is available from VidaSpace. Any information on the function of underfloor heating systems or exact calculations relating to thermal resistance or conductivity of the flooring build-up as a whole must be provided by the supplier of the heating system or the heating engineer.

The most critical time for the wood flooring is during and for 48 hours after the installation. Allowing the temperature or humidity to alter, particularly overnight when temperatures can drop, can cause excessive dimensional changes in the wood.

We recommend using alternative heat sources to the UFH during the installation period and that UFH systems should remain off for the installation period and for at least 48 hours after the installation. When bringing the UFH back into operation, increase the temperature by a maximum of 2°C (3.5°F) each 24-hour period until the normal room temperature is reached.

Note: This also applies when using the UFH after periods of not being used.

We would also recommend a cool down period using the same formula 2°C (3.5°F) each 24-hour period until switched off. Always set the heating to a frost temperature of minimum 12°C (54°F) when not in full usage.

Always set the heating to a frost temperature of minimum 12°C (54°F) when not in full usage.

Commissioning & Usage of Heating, Ventilation & Air Conditioning (HVAC) Systems:

This relates specifically to the transition from construction-phase environmental conditions to normal operating conditions where VidaSpace timber floors are to be installed.

The concern relating to this project type is detailed in the expected Equilibrium Moisture Content (EMC) in the timber material as dictated by its environment:

Construction-Phase Environment Example

Temperature: 15°C

Ambient Relative Humidity (RH): 60%

EMC: 11.14%

Operational Environment Example

Temperature: 21°C

Ambient RH: 35%

EMC: 6.95%

Under the example transition above, the timber flooring will lose over 4% of moisture content once the environmental control system is brought into operation. This equates to ~1% of dimensional contraction (typical 0.22% dimensional change per 1% change in EMC). If this transition is made too quickly, the timber will be subjected to a high level of stress and this can result in surface cracking, gaps between timber elements, distortion of timber elements and other undesired actions.

Because of this, there is a requirement to bring the heating/ac system into operation slowly in order to allow staged-adaptation of the timber to the environment. This should be done as follows:

- Environmental conditions measured and recorded, and the temperature of the system set to that which is present in the environment at that time.
- The system should be allowed to operate at this temperature for at least 24 hours. RH should be monitored and recorded in the environment in this time.
- No more than 2°C increase in the system per 24-hour period with recordings to be made of RH.
- System brought up to operating temperature with each stage recorded and documented over several days with RH to also be recorded.
- An environmental measure should be in place (such as a LogTag temperature and humidity device) to monitor RH and provide an alert when RH levels fall below 35% so that plants or other moisture sources may be introduced.

The optimum performance of the timber flooring will remain between 40–60% RH and between 18–22°C due to the 8% ($\pm 2\%$) moisture content at the time of manufacture. The above process is designed to prevent failure of the timber flooring under sudden exposure to altered environmental conditions. Seasonal gapping can be expected.

Requirements for temporary heating (during the installation at construction phase) in colder months to be operational 24 hours a day remain. All efforts should be made to achieve temperatures of 18°C at the time of timber flooring installation and until the project completion. If RH levels are found to be above 65% at the time of installation, works should be postponed until ventilation and/or dehumidifiers have been introduced in order to provide suitable installation conditions.

Floor Protection:

When VidaSpace floors are installed in a construction environment, they should be adequately protected in order to prevent damage from any following trades.

VidaSpace recommend that a layer of building paper or another suitable breathable membrane is first installed prior to an impact protection layer. The building paper should be installed over the whole floor area and overlapped at joins before being taped on the surface, ensuring not to tape the protection to the wood floor surface. An impact protection layer of fire-retardant hardboard can then be installed over the building paper, leaving the hardboard 50-100mm short of the perimeter to allow ventilation of moisture.

Caution should be taken if using corrugated plastic floor protection because this is non-permeable to moisture and can cause construction moisture to be trapped in the timber, leading to excessive expansion or telegraphing of the floor surface. If this type of protection must be used, always install a layer of overlapped building paper (or another suitable breathable layer) first and ensure it is not left on the floor for any extended period.

Any floor protection should be lifted regularly, ideally every 2-3 weeks, to allow ventilation to the floor on projects with elongated periods between flooring installation and project completion.

Never tape flooring protection directly to the flooring surface because tape adhesive can cause irreparable damage to the floor finish. Overlap paper layer and tape sheets to one another and/or walls and tape impact protection to the paper layer.

Never run underfloor heating systems while floor protection is in place because the protection layers can trap moisture or generate elevated surface temperatures, potentially leading to problems such as excessive expansion or over-drying and shrinkage of the wood material respectively.

©This information Sheet was written by VidaSpace Limited, 20 Roe Street, Levin, 5571, New Zealand.

At the time of writing and publication of this sheet, all information is specified correctly. The photographs used in this sheet are intended only as illustrations. No rights can be derived from them.